

**REGULAR MEETING OF THE BOARD OF DIRECTORS
KAUAI ISLAND UTILITY COOPERATIVE**

Held at 4463 Pahe`e Street

Līhu`e, Kaua`i, Hawai`i

On August 27, 2019

MINUTES

Call to order at 1:00 p.m.

1. Roll Call

1.1 **Present:** Directors Allan Smith (Chair), Dee Crowell, David Iha, Janet Kass, James Mayfield, Calvin Murashige (Secretary), Teofilo Tacbian, Jan TenBruggencate (Vice Chair), and Peter Yukimura (Treasurer); and David Bissell (President and CEO). A quorum of directors were present.

1.2 **In attendance:** Laurel Loo (General Counsel), Karissa Jonas (CFO), Maile Alfiler (Member Services Mgr.), Rick Eckert (Financial Planning & Strategy Mgr.), Carey Koide (T&D Mgr.), Beth Tokioka (Communications Mgr.), Lisa Ubay (HR Mgr.), Michael Yamane (COO & Technology) and Nadine Tipps (Executive Administrator); and two (2) members of the public.

2. Invocation – Director Murashige opened the meeting with prayer.

3. Approval of Agenda - The agenda was approved as circulated.

4. Approval of Minutes

4.1 The 7/30/2019 meeting minutes were approved unanimously. [Motion: TenBruggencate/Murashige]

5. President's Report. David Bissell, President and CEO

5.1 The current Cooperative statistics were reported. (report attached)

5.2 Chair Smith read a letter that he received from RUS, summarising their completion of their Loan Fund and Accounting Review (LFAR) of KIUC for the period of May 1, 2016 through June 30, 2019.

5.2.1 Their review of the cooperative's loan fund transactions indicated that all Construction Fund receipts were accounted for properly, and all Construction Fund disbursements were for proper loan program purposes and amounts.

5.2.2 They expressed their appreciation for the cooperation and assistance of KIUC during the review and the other courtesies extended during their visit.

6. Financial Report: Karissa Jonas, CFO reported.

6.1 CoBank Reporting –

6.1.1 Met with CoBank while at the NRECA Accounting conference.

- 6.1.2 CoBank informed KIUC that they would prefer to revise the Credit Agreement at the same time they are providing the documents for the upcoming CWP Loan.

CFC Reporting –

- 6.1.3 The CFC term loan interest rate was re-priced from 3.30% (3.55% less 0.25% in discounts) to 3.69% (3.94% less 0.25% in discounts) for four years, till maturity.

6.2 RUS Reporting –

- 6.2.1 In accordance with KIUC’s RUS approved Load Forecast Work Plan, KIUC is required to submit a new load forecast to RUS for review and approval every 36 months and then submit updates to the load forecast to RUS for review and approval in each intervening year.

- 6.2.2 In 2018 KIUC submitted a new load forecast to RUS.

- 6.2.3 On 7/30/19, KIUC submitted its first update to the load forecast to RUS.

- 6.3 The July 2019 preliminary financials were reviewed. (scorecard attached)

- 6.4 Brief discussion about air conditioners.

7. **NRECA Hawaii Director Report – Director David Iha**

- 7.1 Director Iha reported that KIUC hosted NRECA CEO Jim Matheson and his family here on Kauai. It was a good opportunity to get to know his family, also with the facilities tours and presentation here at KIUC, CEO Matheson was able to see what KIUC is doing. Thank you to all that made their visit nice.

8. **Committee Reports**

8.1 **Executive – Committee Chair, Jan TenBruggencate**

- 8.1.1 The committee met on August 19th.

- 8.1.2 There was discussion of an NRECA Director from the state of Hawaii. This election will be held under New Business.

- 8.1.3 Committee Chair TenBruggencate and Chair Smith received a letter from Puanani Gonsalves, who recommended our Youth Tours traveling to Washington D.C. each year should visit the Japanese American Memorial, which was designed by a store keeper in Kekaha, Hawaii, who still lives here in Kekaha. This information has been passed on to Shelley Paik for future Youth Tours to D.C.

8.2 **Finance & Audit –Committee Chair, Peter Yukimura**

- 8.2.1 The committee met on August 19th.

- 8.2.2 One action item, Ililiula 36” Siphon Replacement, will be taken up under New Business.

- 8.2.3 Discussed the 2020 Board Budget, but no action was needed.

- 8.2.4 CFO Jonas reported the financials.

8.3 **Government Relations/Legislative – Committee Chair, Phil Tachian**

- 8.3.1 The committee met on August 19th.

- 8.3.2 Director Mayfield stated if he is re-elected to the KIUC Board next year, he would like to attend the Legislative Conference in D.C. again.

- 8.3.3 There was discussion about the IBEW (International Brotherhood of Electrical Workers) from the KIUC Annual Meeting.
 - (a) CEO Bissell has met with them on numerous occasions, and will continue to.
 - (b) Chair Smith had asked CEO Bissell to draft a letter to them.

8.4 Member Relations –Committee Chair, Calvin Murashige

- 8.4.1 Met on August 19th.
- 8.4.2 Received reports from Member Services and Communications.

8.5 Policy – Committee Chair, Dee Crowell

- 8.5.1 Met on August 19th.
- 8.5.2 Reviewed Board Policy No. 11, Patronage Capital Allocation and Retirement Policy. After discussion, this policy will be re-reviewed next month.
- 8.5.3 Referred some sample policies that are on NRECA’s website for review.

8.6 Strategic Planning –Committee Chair, James Mayfield

- 8.6.1 Met on August 19th.
- 8.6.2 Discussed information of Electrical Vehicles (EVs) on Kauai.
 - (a) Discussed the trend of the EV growth over the last few years, and a first draft of the gross profitability of electric sales to EVs.
 - (b) Even though it is growing, it is growing at a small base. It will be a while until these make up an appreciable percentage of our total.

9. Charitable Foundation (CF) Board – Teofilo Tacbian, President

- 9.1 The CF Board met on August 20th.
- 9.2 Balance of \$67,232 after paying \$1,500 donation to the Kauai Academy of Arts.
- 9.3 KEO assisted one families in July in the amount of \$200, bringing their donation balance to \$7,543.
- 9.4 The Makana program will be featured in our next Currents.
- 9.5 The Golf Tournament Committee, Chaired by Director Crowell continues to iron out the details of the tournament. They will be calling on all Directors to assist.
- 9.6 A request for reflective vests for seniors, who walk early in the morning, was taken under advisement and deferred to their next meeting in September.
 - 9.6.1 Chair Smith reported that he met with the West Kauai Rotary Club, and it is also for youngsters that walk out of the valley in the early mornings.
 - 9.6.2 Anyone that wants to make a request from the Charitable Foundation, needs to fill out an application.

10. Public Testimony. Members Marj Dente and Steve Parsons provided oral testimony to the Board of Directors.

A recess was taken at 1:40 p.m. The meeting reconvened at 1:50 p.m.

11. New Business

11.1 Election of NRECA Director – Hawaii

- 11.1.1 A recommendation was made by Executive Committee Chair TenBruggencate to re-elect KIUC Director David Iha as the NRECA Director for Hawaii for an additional 2-year term commencing with the adjournment of the 2020 NRECA Annual meeting and ending with the adjournment of the 2022 NRECA Annual meeting.
- 11.1.2 The floor was opened to additional nominations. None were received.
- 11.1.3 The recommendation carried unanimously.

IN FAVOR:	Crowell, Iha, Kass, Mayfield, Murashige, Smith, Tactian, TenBruggencate & Yukimura	Total – 9
OPPOSED:	None	Total – 0
EXCUSED:	None	Total – 0

11.2 Iliiliula 36” Siphon Replacement

- 11.2.1 F&A Committee Chair Yukimura reported the committee discussed and recommended approval of the unbudgeted amount of \$419k for the Iliiliula 36” Siphon Replacement.
- 11.2.2 After brief discussion, a motion to approve the Iliiliula 36” Siphon Replacement carried with one opposition. [Motion: Mayfield/Iha]

IN FAVOR:	Crowell, Iha, Mayfield, Murashige, Smith, Tactian, TenBruggencate & Yukimura	Total – 8
OPPOSED:	Kass	Total – 1
EXCUSED:	None	Total – 0

11.3 Discussion of KIUC Membership in Cooperative Response Center

- 11.3.1 CEO Bissell reported to the Board that this would be joining another cooperative, the Cooperative Response Center (CRC).
- 11.3.2 Maile Alfiler advised that KIUC is looking at CRC’s assistance when there is an influx of calls, after hours and also during outages, the extra calls would roll over to them. They are available 24/7 and they also interface with our current NISC system. We are currently doing testing, and this is just discussion. Will keep the Board updated on this.
- 11.3.3 Since CRC is a cooperative, we would become a member.
- 11.3.4 After discussion, a motion that KIUC become a member of the Cooperative Response Center carried unanimously. [Motion: Kass/Murashige]

IN FAVOR:	Crowell, Iha, Kass, Mayfield, Murashige, Smith, Tactian, TenBruggencate & Yukimura	Total – 9
OPPOSED:	None	Total – 0
EXCUSED:	None	Total – 0

12. **Calendar:**

- 12.1 **September 2, 2019** – HOLIDAY, KIUC Offices Closed
- 12.2 **September 11-13, 2019** – HCPO Conference
- 12.3 **September 16, 2019** – Board Committee Meetings (9:00am., MCR)
- 12.4 **September 19, 2019** – Board Meeting (1:00pm., KIUC Main Conf Rm)
- 12.5 **September 24-26, 2019** – Region 7&9 Meeting
- 12.6 **September 28, 2019** – Paws for Celebration (5:00pm., Kauai Marriott Resort)

13. **Executive Session.** At 2:10 p.m. the Board recessed the meeting to enter into an Executive Session closed to the public on matters limited to those specified in Section II. A. 2. of Board Policy No. 16. The items to be discussed in the Executive Session are matters of a proprietary or financial nature, public disclosure of which could affect on-going or potential negotiations or legal or administrative proceedings and human resource issues related to the hiring, evaluating, dismissing or disciplining an officer or employee and a matter requiring legal consultation on issues pertaining to the powers, duties, privileges, immunities and liabilities of the Board of Directors.

14. **Adjournment.** The open session of the meeting reconvened at 2:38 p.m. Director Kass moved to adjourn the meeting; the motion was seconded by Director Murashige. All directors present voted in favor of the motion and it passed unanimously.

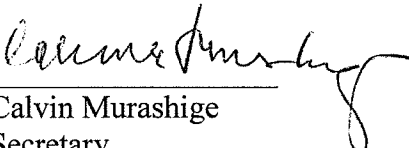

Calvin Murashige
Secretary



President's Report

August 27, 2019

David Bissell, President and CEO

President's Report

David Bissell, President and CEO
August 27, 2019

Safety (July)

	Month	2019 YTD	2018 YTD
Recordable Incidents	1	1	1
Days Away/Restricted	0	0	133

Availability and Reliability:

	Month	2019 YTD	2018 YTD
Reportable Outages	4	27	28
Average Outage Hours Per Customer	2.11	3.79	0.61

Efficiency

	Month	2019 YTD
Net Plant Heat Rate	9,752	9,318
Peak Demand (MW)	77.24	77.24

Residential Rates:

August 2019	\$0.331/kwh Up \$0.014 from July
-------------	----------------------------------

Islandwide Outage 7/21/19 – Pre-fault – 44.59MW Generation

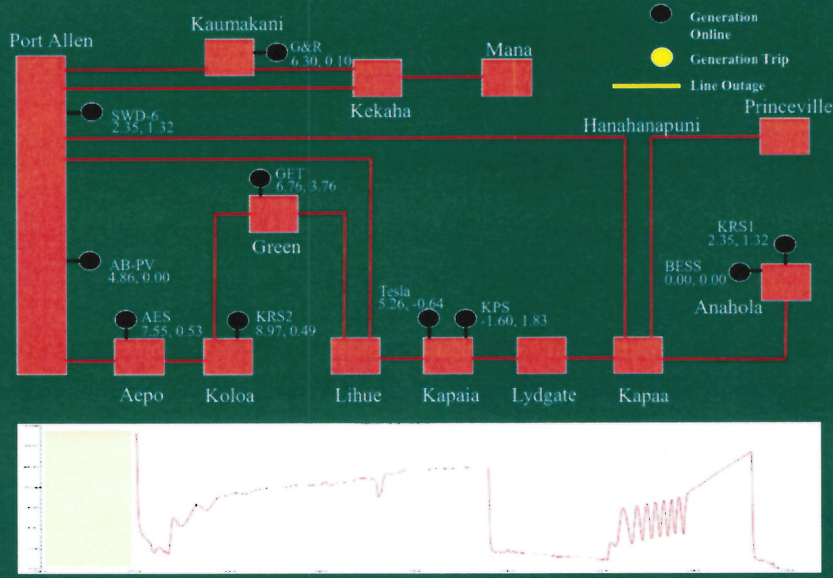

~0.57 seconds after KPS 13.8kV bkr's open – 17.9MW tripped, 4.71MW gen

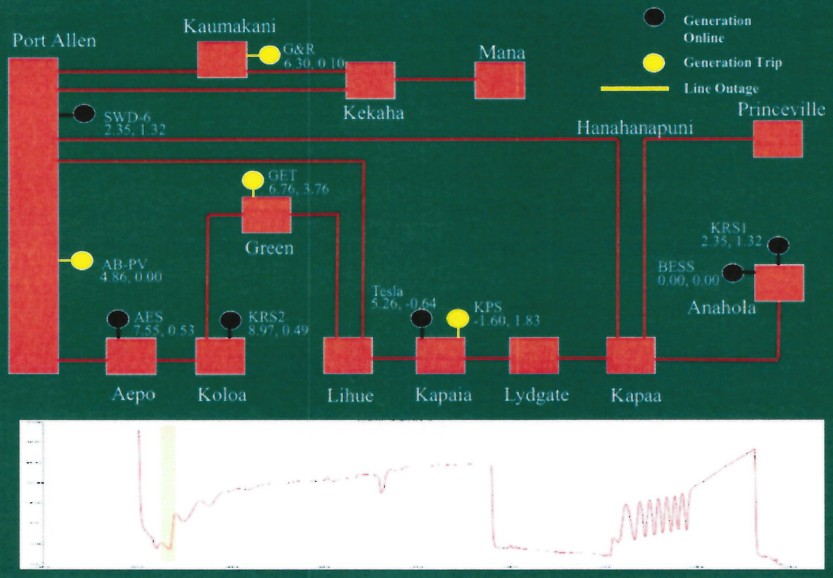

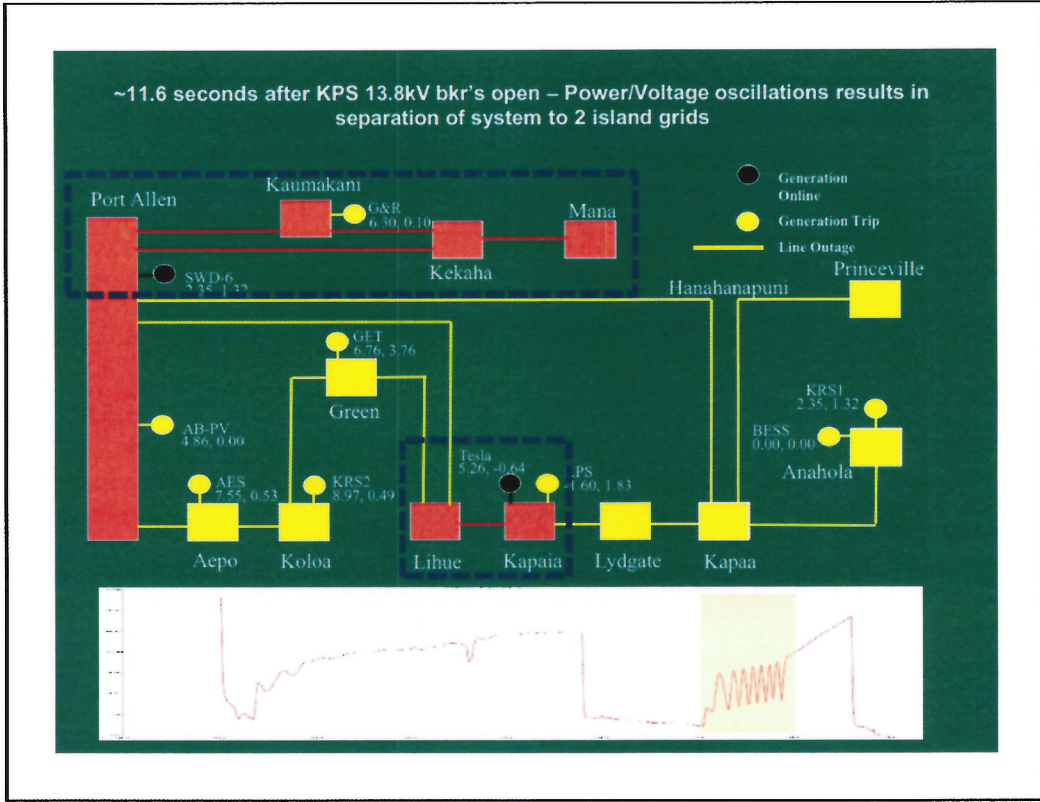
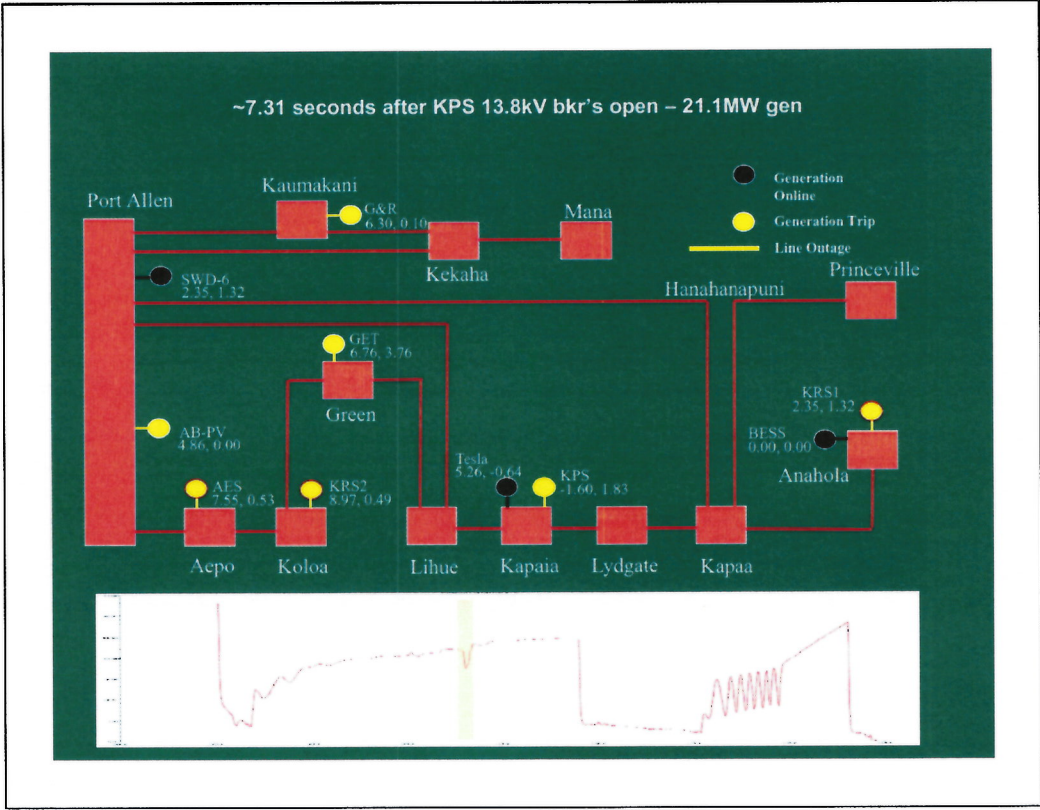

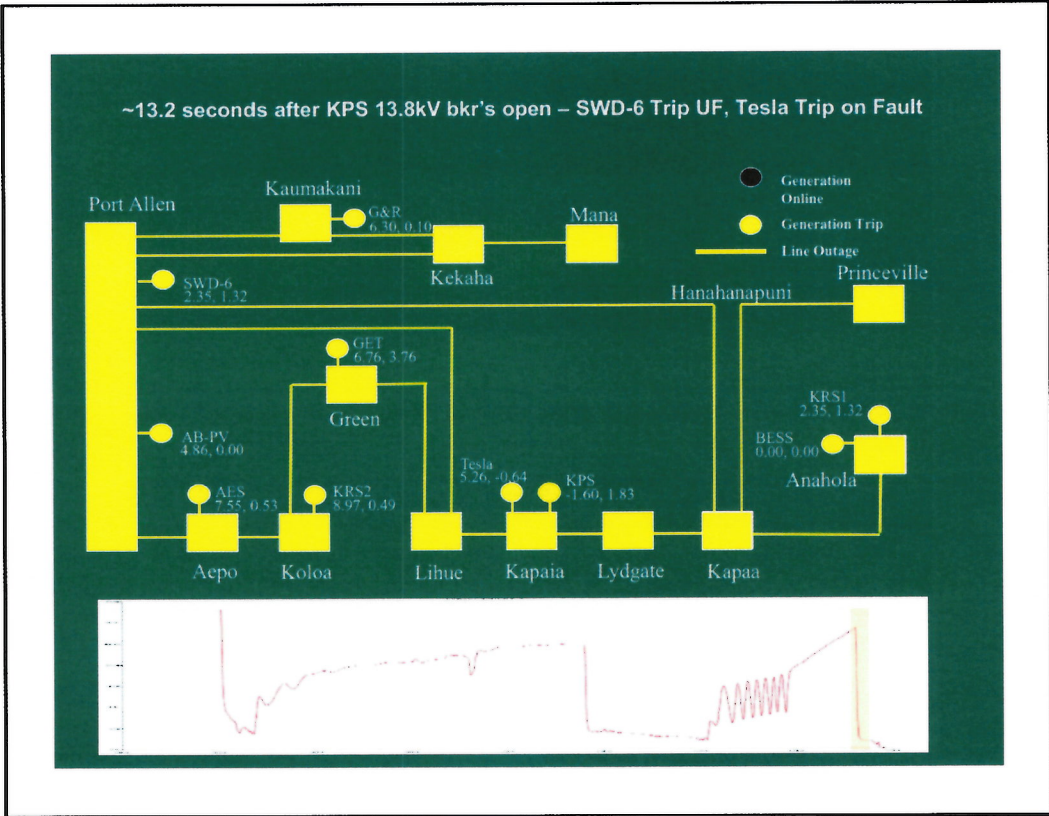

Outage Restoration Summary

July 21, 2019	KPS Bus Fault induces Island wide outage
2:12pm	Begin initial restoration
2:47pm	Closed back on fault during restoration (Island wide outage)
3:04pm	50% Restored
4:15pm	All loads restored
5:06pm	

Rolling Outage Statistics

July 21, 2019	11:18pm-12:18am
July 22, 2019	6:07am- 5:02pm
Feeders affected	34
% Feeders affected	81%
Members affected	27379
Average # rolls/feeder	2.62
Average duration/roll	28.76 minutes

8

Member Engagement - July

- **Social Media**
 - Facebook posts 58
 - 17 Kapaia outage
 - 13 Other outages
 - 23 General information
 - New likes on FB page 802
 - Total people engaged with page 221,338
 - Constant Contact – Email
 - 3 emails sent to 14,000 subscribers
 - 2 for Kapaia outage and 1 general update
 - Open rate 50%
- **Member Services**
 - Call center interactions down 17.6%
 - Credit card payment sup 14.5%
 - New Smart Hub Registrations 158



Other Items of Note

- KIUC first in nation in Battery Storage per consumer – SEPA
- Hosted NRECA President Jim Matheson for facilities tour
- Held Annual Membership Meeting



Mahalo!

Financial Scorecard

Class	YTD		Percent Change
	Prior Year	Actual	
Residential (D)	100,337	100,552	0.2%
Small Comm (G)	36,349	38,161	5.0%
Large Comm (J)	28,391	28,609	0.8%
Lrg Pwr Primary (L)	29,896	28,884	-3.4%
Lrg Pwr Secondary (P)	61,160	60,619	-0.9%
Street Lighting (SL)	497	470	-5.5%
Irrigation	1,486	181	-87.8%
Total	258,115	257,476	-0.2%

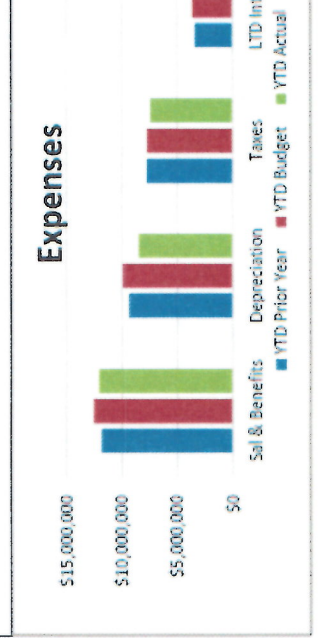
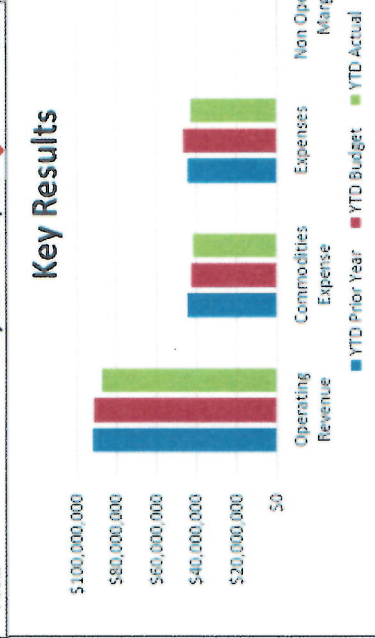
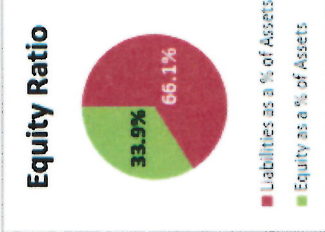
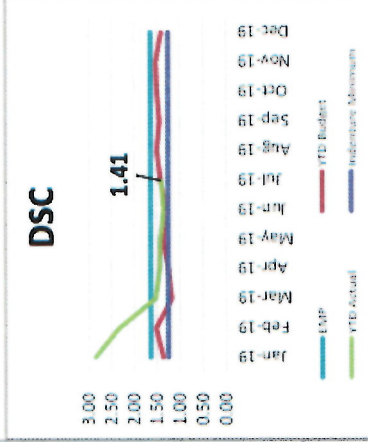
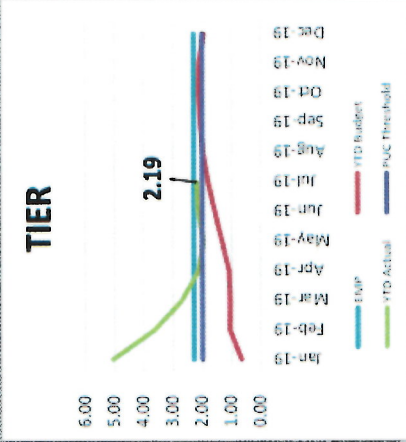

Liquidity	
	YTD Actual
Cash	\$6,161,412
Short-Term Investments	\$13,060,553
Cushion of Credit	\$15,563,731
Line of Credit Available	\$40,000,000
Line of Credit Drawn	\$0

